

**SPECIFICATIONS**

| MODEL  | POWER IN WATTS/HP | SPEED IN RPM | VOLTAGE IN DC | CURR. IN AMPS | RATIO | O/P SPEED IN RPM | TORQUE IN KG-CM | INSL. INSL. | DUTY CYCLE | PROTEC | ENCL. | WEIGHT (KG) |
|--------|-------------------|--------------|---------------|---------------|-------|------------------|-----------------|-------------|------------|--------|-------|-------------|
| M02SWA | 20 / 0.03         | 1700         | 12 / 24       | 2.0/1.0       | 55    | 30               | 19              | B           | S1         | IP44   | TENV  | 1.4         |
| M02SWB | 20 / 0.03         | 1700         | 12 / 24       | 2.0/1.0       | 27.5  | 70               | 10              | B           | S1         | IP44   | TENV  |             |
| M02SWC | 20 / 0.03         | 2200         | 12 / 24       | 2.0/1.0       | 18    | 120              | 8               | B           | S1         | IP44   | TENV  |             |
| M02SWD | 20 / 0.03         | 3000         | 12 / 24       | 2.0/1.0       | 18    | 160              | 5               | B           | S1         | IP44   | TENV  |             |
| M03SWA | 40 / 0.05         | 1700         | 12 / 24       | 4.0/2.0       | 55    | 30               | 38              | B           | S1         | IP44   | TENV  | 1.4         |
| M03SWB | 40 / 0.05         | 1700         | 12 / 24       | 4.0/2.0       | 27.5  | 70               | 19              | B           | S1         | IP44   | TENV  |             |
| M03SWC | 40 / 0.05         | 2200         | 12 / 24       | 4.0/2.0       | 18    | 120              | 16              | B           | S1         | IP44   | TENV  |             |
| M03SWD | 40 / 0.05         | 3000         | 12 / 24       | 4.0/2.0       | 18    | 160              | 11              | B           | S1         | IP44   | TENV  |             |



**PMDC MOTOR.**

TITLE 63DIA WORM GEARED MOTOR

REVISION NO. 00 REVISION DATE 17/08/2009

DRAWN BY. MANOHAR APPROVED BY R.S.KUNDGOLKAR

**MMC ELECTRIC COMPANY PVT.LTD. BELGAUM.**

SHEET 1 OF 1 MATERIAL N.T.S.

DRG.NO. MI-SM/6.2-M

| REV.NO | DATE | DESCRIPTION | DRN.BY | APD.BY |
|--------|------|-------------|--------|--------|
|        |      |             |        |        |

ALL DIMENSIONS ARE IN MM.

INSL.CLASS : FLANGE

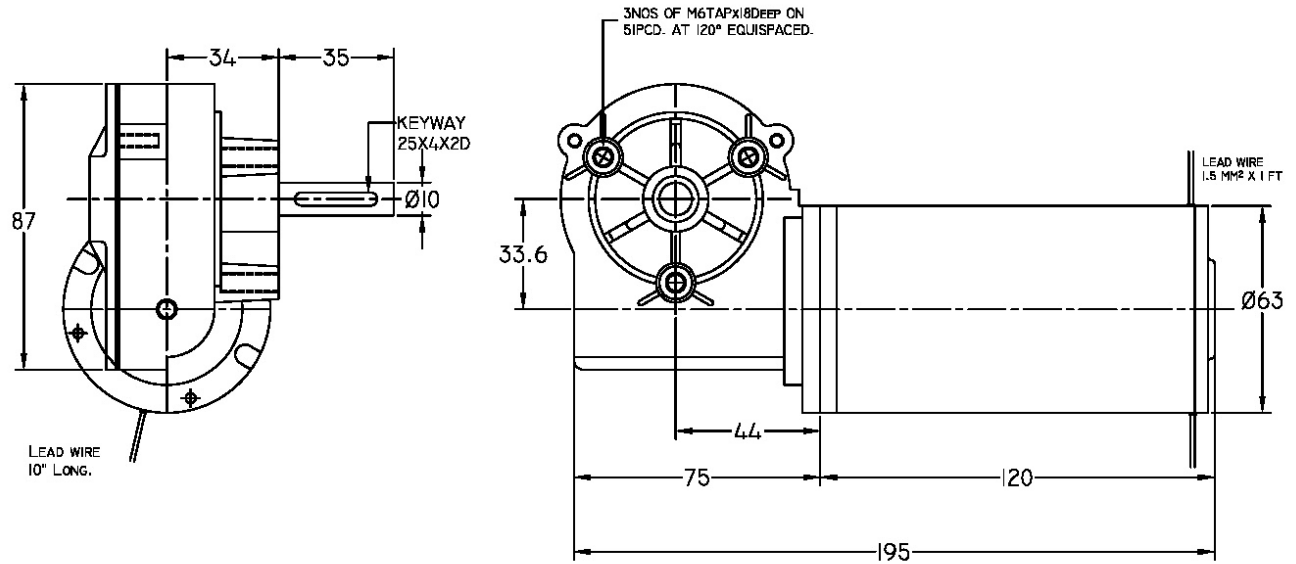

**SPECIFICATIONS**

| MODEL                     | POWER IN WATTS/HP | SPEED IN RPM | VOLTAGE IN DC | CURR. IN AMPS | RATIO  | OP SPEED IN RPM | TORQUE IN KG-CM | INSL. INSL. | DUTY CYCLE | PROTEC | ENCL. | WEIGHT (KG) |
|---------------------------|-------------------|--------------|---------------|---------------|--------|-----------------|-----------------|-------------|------------|--------|-------|-------------|
| M04SWA                    | 60/0.08           | 1700         | 12/24         | 6.2/3.1       | 55     | 30              | 57              | B           | S1         | IP44   | TENV  | 2.0         |
| M04SWB                    | 60/0.08           | 1700         | 12/24         | 6.2/3.1       | 27.5   | 70              | 29              | B           | S1         | IP44   | TENV  |             |
| M04SWC                    | 60/0.08           | 2200         | 12/24         | 6.2/3.1       | 18     | 120             | 24              | B           | S1         | IP44   | TENV  |             |
| M04SWD                    | 60/0.08           | 3000         | 12/24         | 6.2/3.1       | 18     | 160             | 17              | B           | S1         | IP44   | TENV  |             |
| <b>MOUNTING : FLANGE</b>  |                   |              |               |               |        |                 |                 |             |            |        |       |             |
| ALL DIMENSIONS ARE IN MM. |                   |              |               |               |        |                 |                 |             |            |        |       |             |
| REV.NO                    | DATE              | DESCRIPTION  |               | DRN.BY        | APD.BY |                 |                 |             |            |        |       |             |



**PMDC MOTOR.**

|              |                         |  |   |    |          |
|--------------|-------------------------|--|---|----|----------|
| TITLE        | 63DIA WORM GEARED MOTOR |  | <b>MMC ELECTRIC<br/>COMPANY PVT.LTD.<br/>BELGAUM.</b> |    |          |
| REVISION NO. | REVISION DATE.          |  |   |    |          |
| 00           | 17/08/2009              |  |   |    |          |
| DRAWN BY.    | APPROVED BY             |  |   |    |          |
| MANOHAR      | R.S.KUNDGOLKAR          |  | SHEET   | OF | MATERIAL |
|              |                         |  | SCALE.  |    | ---      |
|              |                         |  | N.T.S.  |    |          |
| DRG.NO.      | MI-SM/7.2-M             |  |   |    |          |

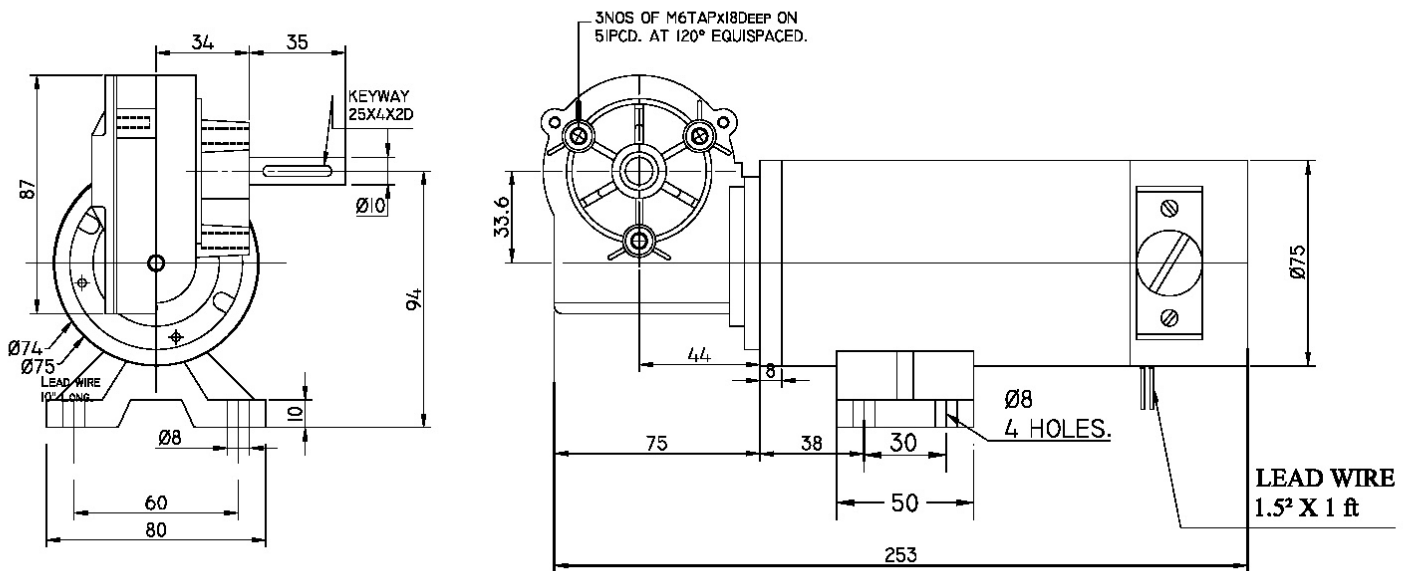

NOTE: ALL UNSPECIFIED DIMENSIONS ARE HAVING TOLERANCE OF ±0.1MM.

| SPECIFICATIONS               |                   |              |               |               |       |                  |                 |             |            |        |       | <b>DYNAPLUX</b> |              | <b>PMDC MOTOR.</b>      |   |                       |                |  |
|------------------------------|-------------------|--------------|---------------|---------------|-------|------------------|-----------------|-------------|------------|--------|-------|-----------------|--------------|-------------------------|---|-----------------------|----------------|--|
| MODEL                        | POWER IN WATTS/HP | SPEED IN RPM | VOLTAGE IN DC | CURR. IN AMPS | RATIO | O/P SPEED IN RPM | TORQUE IN KG-CM | INSL. INSL. | DUTY CYCLE | PROTEC | ENCL. | WEIGHT (KG)     | TITLE        | 75DIA WORM GEARED MOTOR | <b>MMC ELECTRIC COMPANY PVT.LTD. BELGAUM.</b> |                       |                |  |
| M2BWA                        | 75 / 0.10         | 1700         | 12 / 24       | 8.0 / 4.0     | 55    | 30               | 80              | B           | S1         | IP44   | TENV  | 4.8             | REVISION NO. | REVISION DATE.          |   | SHEET   OF   MATERIAL |                |  |
| M2BWB                        | 75 / 0.10         | 1700         | 12 / 24       | 8.0 / 4.0     | 27.5  | 70               | 40              | B           | S1         | IP44   | TENV  |                 | 00           | 17/08/2009              |   |                       | SCALE. N.T.S.  |  |
| M2BWC                        | 75 / 0.10         | 2200         | 12 / 24       | 8.0 / 4.0     | 18    | 120              | 30              | B           | S1         | IP44   | TENV  |                 | DRAWN BY.    | APPROVED BY.            |   |                       |                |  |
| M2BWD                        | 75 / 0.10         | 3000         | 12 / 24       | 8.0 / 4.0     | 18    | 160              | 20              | B           | S1         | IP44   | TENV  |                 | MANOHAR      | R.S.KUNDGOLKAR          | DRG.NO.                                       |                       | MI-75/109-M.01 |  |
| INSL.CLASS : FOOT CUM FLANGE |                   |              |               |               |       |                  |                 |             |            |        |       |                 |              |                         |   |                       |                |  |
| ALL DIMENSIONS ARE IN MM.    |                   |              |               |               |       |                  |                 |             |            |        |       | REV.NO          | DATE         | DESCRIPTION             | DRN.BY  | APD.BY                |                |  |